

Introduction

The Wireless Rain-Clik acts as a switch to break the circuit to the solenoid valves of the irrigation system when a rain event occurs. This allows the timer to advance as scheduled, but keeps the valves from opening the water flow. Once the Wireless Rain-Clik has dried sufficiently, the switch closes again to allow for normal operation.

The Wireless Rain/Freeze-Clik includes a freeze sensor that is designed to keep the system from operating at or below 37°F (3°C). At higher temperatures, it will close the circuit for normal sprinkler operation.

Mounting

Standard Mounting

Using the screws provided, mount the Wireless Rain-Clik on any surface where it will be exposed to unobstructed rainfall, but away from sprinkler spray. The switch housing portion must be upright (as pictured), but the swivel-bracket can be moved for mounting on any angled surface. Loosen the locknut and screw before swiveling the bracket, and then re-tighten.

Gutter Mount (SGM Sold Separately)

The sensor gutter mount can be purchased as an optional accessory for your Wireless Rain-Clik (order P/N SGM). The SGM allows the Wireless Rain-Clik to be mounted directly to the side of a gutter. To install your Wireless Rain-Clik on a gutter, remove the screw, nut, and standard metal extension arm, and reinstall the screw and gutter mount. Position the mount on gutter edge and twist the thumbscrew to secure it.

Helpful Hints for Mounting

A. Choose a location such as on the side of a building or post. The closer the Wireless Rain-Clik is to the controller, the better reception will be. DO NOT EXCEED 200' (61 m).

B. Correct placement of the Wireless Rain/Freeze-Clik model is important for accurate temperature sensing. Choose a location out of direct sunlight.

C. As described in the "Operation" section of this manual, reset rate refers to the time it takes the Wireless Rain-Clik to dry out sufficiently for the sprinkler system to come back on. The mounting location will affect this rate and should be taken into consideration during extreme conditions. For example, mounting the Wireless Rain-Clik on a very sunny, southern end of a building may cause the Wireless Rain-Clik to dry out sooner than desired. Similarly, mounting on the northern end of a building with constant shade may keep the Wireless Rain-Clik from drying soon enough.

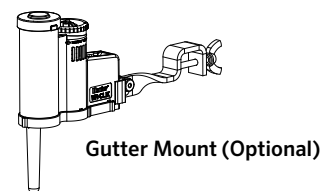
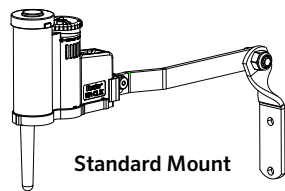

Sensor

- There is nothing to set up with this unit after installation.
- The unit can be tested stand-alone as follows: Press and hold the post on the quick response section. Within three seconds of pressing and holding this post down, the LED protruding from the potting should blink once. Release the post; within three seconds the LED should blink once again (Figure 1).

Receiver

- Using the hardware included, mount the receiver to the wall (use included wall anchors if needed). Put the rubber cover/gasket under the unit when attaching it outdoors.

Wiring to Your Irrigation System

WARNING! This unit is designed to be installed in conjunction with 24 VAC circuits only. Do not use with 110 or 220 VAC circuits.

Receiver Installation, Hunter Controllers (Figure 2)

1. Attach the two yellow wires to the AC terminals of the controller (polarity does not matter).
2. Attach the blue wire to one SEN terminal and the white wire to the other SEN terminal.
3. For Hydrawise™ controllers, attach the white wire to the SEN COM terminal and the blue wire to SEN-1 or SEN-2 terminals.
4. Leave the orange wire unconnected.

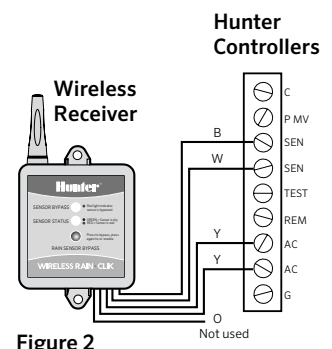

Receiver Installation, Other Controllers:

Normally Closed Sensor Applications (Figure 3)

1. Attach the two yellow wires to the AC terminals of the controllers (polarity does not matter).
2. To attach the receiver to this type of controller, attach the blue wire and the white wire to the sensor terminals of the controller, or in-line with the valve common.
3. Leave the orange wire unconnected.

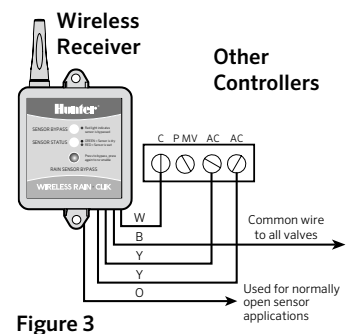

Normally Open Sensor Applications

1. Some controllers on the market require a normally open rain sensor. To attach the receiver to this type of controller, attach the blue wire and the orange wire to the controller's sensor input.

Setting the Transmitter Address at the Receiver

Units purchased as a kit will already have their address learned, so no addressing is necessary. However, if the receiver or transmitter is replaced, you must reset the address.

Each transmitter produced has a unique address hard-coded into it. A receiver must learn this address to work with that transmitter. This step will only be necessary if transmitters and receivers are purchased separately.

1. Prior to applying power (yellow wires) to the receiver, press and hold the push button on the receiver.
2. With the push button held, apply power to the receiver. The receiver's "sensor status" LED should light up yellow, which indicates the receiver is ready to learn an address.
3. Push and hold the quick response post on the transmitter/sensor.

4. Within four seconds, the receiver's "sensor status" LED will turn red.
5. Release the transmitter/sensor's quick response post and within four seconds the LED on the receiver will turn green. The address is now learned and will be retained even after a power outage.

Operation

The receiver has two LEDs, which indicate the state of the system. The STATUS LED will be RED when the sensor is wet (watering disabled), and GREEN when the sensor is dry (watering enabled). There is also a RED BYPASS LED on the receiver. If this LED is lit, the rain sensor is bypassed and watering will always be allowed. Even though the sensor is bypassed, the STATUS LED will continue to alert you of the state of the sensor (Wet or Dry).

Adjustment and Operation

The Wireless Rain-Click keeps irrigation from starting or continuing after rainfall or freezing conditions (Wireless Rain/Freeze-Click).

The time that it takes the Wireless Rain-Click to reset for normal sprinkler operation after rain has stopped is determined by weather conditions (e.g., wind, sunlight, humidity). These conditions will determine how fast the discs dry out. Since the turf is experiencing the same conditions, their respective drying rates will roughly parallel each other.

There is an adjustment capability on the Wireless Rain-Click that will slow down the reset rate. By closing the vent (Figure 4) to completely or partially cover the ventilation slots, the discs will dry more slowly. This adjustment can compensate for an overly sunny installation location, or peculiar soil conditions. Experience will best determine the ideal vent setting.

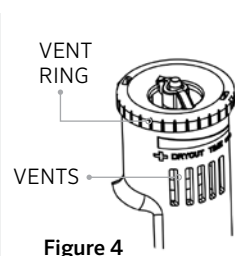

No adjustment is required for the freeze sensor portion of the wireless Rain/Freeze-Click. The Wireless Rain/Freeze-Click will automatically disable irrigation when temperatures fall below 37°F (3°C). Although Freeze Sensors are designed to automatically prevent watering near or below freezing conditions, use visual checks and prudent manual watering suspensions in conjunction with any freeze sensor.

Bypassing the Sensor

The sensor may be bypassed by using the built in bypass feature on the X-Core®, Pro-C®, ICC2, and I-Core®. On other controllers, bypass the sensor by pressing the "BYPASS" button on the receiver. The RED BYPASS LED on the receiver will light up when the sensor is bypassed. Pressing the "BYPASS" button again will cause the RED BYPASS LED to turn off, which re-enables the sensor.

Battery Life

The Wireless Rain-Click sensor is designed to work daily for up to 10 years with the maintenance-free battery. The sealed unit is available as a replacement part. If you need to change the transmitter, the receiver must learn the new transmitter address.

There is no required maintenance for the unit. The Wireless Rain Sensor does not have to be removed or covered during winterization.

Troubleshooting

Follow these simple checks before replacing the unit:

System Will Not Come On

- A. First, check to see that the Wireless Rain-Click discs are dry and the switch "clicks" on and off freely by pressing the top of the spindle.
- B. Next, look for breaks in the wire leading to the Wireless Rain-Click receiver. Check all wire junctions.
- C. Verify temperature (for Rain/Freeze-Click installations).

System Will Not Shut Off Even After Heavy Rainfall

- A. Check wiring for correctness (see "Wiring to Your Irrigation System" on the previous page).
- B. Is the rainfall hitting the sensor? Check for obstructions to rainfall, such as overhangs, trees, or walls.

Manufactured under U.S. Patent 6,570,109 B2

All Rain-Click models are listed by Underwriters Laboratories Inc. (UL). Samples of these devices have been evaluated by UL and meet applicable UL safety standards.

FCC Compliance Notice

This device complies with part 15 of the FCC rules. Operation is subject to the following two conditions:

1. This device may not cause harmful interference, and;
2. This device must accept any interference that may be received, including interference that may cause undesired operation.

Sensor FCC ID: M3UWRCE

This equipment has been tested and found to comply with the limits for a class B digital device, pursuant to part 15 of the FCC Rules.

These limits are designed to provide reasonable protection against harmful interference in a residential installation. This equipment generates, uses, and can radiate radio frequency energy, and if not installed and used in accordance with the instructions, may cause harmful interference to radio communications. However, there is no guarantee that interference will not occur in a particular installation. If this equipment does cause harmful interference to radio or television reception, which can be determined by turning the equipment off and on, the user is encouraged to try to correct the interference by one or more of the following measures:

- Reorient or relocate the receiving antenna.
- Increase the separation between the equipment and receiver.
- Connect the equipment into an outlet on a circuit different from that to which the receiver is connected.
- Consult the dealer or an experienced radio/TV technician for help.

Industry Canada Notice

Sensor - IC:2772A-WRCE

Receiver - IC:2772A-WRCER

Operation is subject to the following two conditions:

This device may not cause harmful interference and

This device must accept any interference received, including interference that may cause undesired operation.

CE NOTICE: This notice applies only to models WR-CLIK and WRF-CLIK

		Important Notice: Low power RF product operating in 869.700-870.000 MHz band for indoor or outdoor home and commercial use.	
		Member states in the EU with restrictive use for this product are crossed out.	
AUS	B	DK	FIN
F	D	GR	IRE
I	LUX	NL	P
E	S	UK	

MAXIMUM OUTPUT POWER

Frequency Band (MHz)	Maximum Power (mW)
433.05 - 434.790	0.1